

# PULSE MODULATION CIRCUIT TECHNIQUES FOR NONLINEAR DYNAMICAL SYSTEMS

Takashi Morie, Souta Sakabayashi, Hiroshi Ando, Makoto Nagata, and Atsushi Iwata

*Faculty of Engineering, Hiroshima University  
Higashi-Hiroshima, 739-8527 JAPAN  
morie@dsl.hiroshima-u.ac.jp*

## Abstract—

This paper proposes new circuit techniques for large-scale integrated nonlinear dynamical systems using PWM and/or PPM methods. The proposed circuits implement discrete-time continuous-state dynamics by analog processing in time domain. A chaotic neuron circuit and a nonlinear oscillator circuit are presented. The SPICE simulation results demonstrate high accurate calculation by the proposed approach.

## I. INTRODUCTION

Recent many reports in neural information processing demonstrate that nonlinear analog dynamics play an important role. Chaotic neural networks and nonlinear oscillator networks are the typical examples. However, conventional neural hardware (VLSI implementation of neural networks) hardly implements such nonlinear dynamics. The backpropagation networks, which are often implemented by conventional neural chips, are layer-type feed-forward networks and have no dynamics. Boltzmann machines have symmetrical connections, thus their dynamics always lead to fixed-point steady states, and chaotic behavior or oscillation is never observed.

Circuit architectures in conventional neural chips are classified into digital and analog. Digital approaches have high precision and controllability, but cannot implement analog dynamics essentially. Analog approaches are obviously suitable for realizing analog dynamical systems, but the calculation precision is affected by various non-idealities in circuit components. Moreover, it is not easy in analog approaches to achieve arbitrary nonlinear, non-monotone transformation.

We have already proposed a new circuit technique generating arbitrary nonlinear functions by using a pulse-width modulation (PWM) method [1]. We have also demonstrated that discrete-time, continuous-state nonlinear dynamical systems can be constructed by using this method [2]. We consider the PWM method as one of the pulse modulation approaches that are basic techniques for new analog-digital merged circuit archi-

ture [3]. These approaches are suitable for large-scale integration of analog processing circuits because they match the scaling trend in the Si CMOS technology and lead to low voltage operation. They also achieve lower power consumption operation than the traditional digital approach.

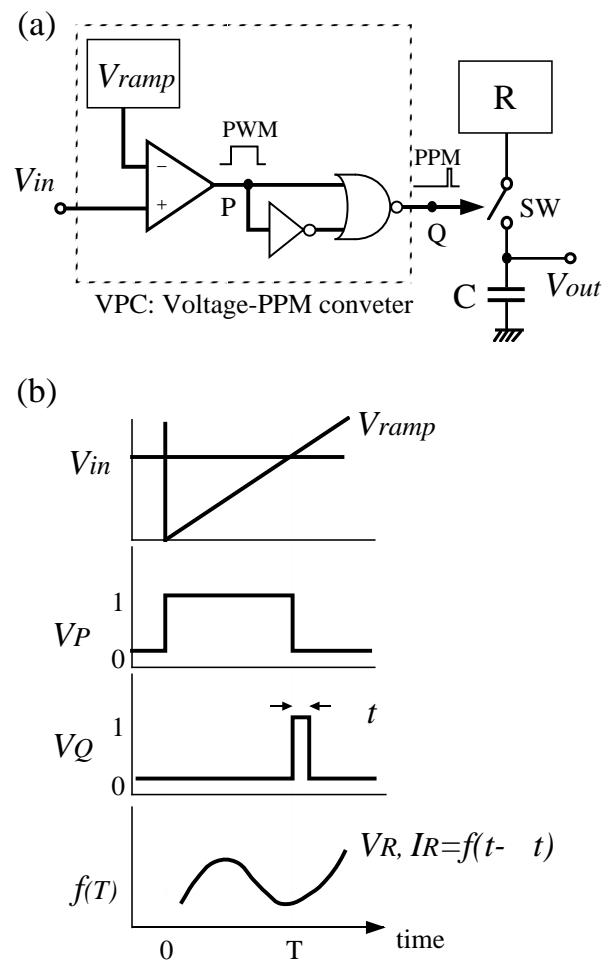

Figure 1: Arbitrary nonlinear transformation circuit

However, the previously proposed PWM circuit technique [1] needs plural reference waveforms corresponding to the inverse function of the expected nonlinear transfer function and plural comparators of which number is equal to that of monotone intervals. These requirements increase circuit complexity and power consumption.

In this paper, we propose new circuit techniques for nonlinear dynamical systems using pulse-width and/or pulse-phase modulation (PWM/PPM) methods. The basic circuit is very simple and the calculation precision is much more improved than the previous one.

## II. BASIC CIRCUIT CONFIGURATION

### A. Basic Circuit for Arbitrary Nonlinear Transformation

Our basic circuit that achieves arbitrary nonlinear transformation is shown in Fig. 1. This circuit generates an arbitrary non-monotone function with only one comparator. The basic operation of this circuit is as follows:

1. The input voltage  $V_{in}$  is transformed into a PWM pulse having width  $T$ . This transformation can be achieved by comparing  $V_{in}$  with a ramped reference signal voltage  $V_{ramp}$ . The reference signal is usually linearly ramped, so  $T \propto V_{in}$ .
2. The PWM pulse is transformed into a PPM pulse that has a certain small width  $\Delta t$  and its leading edge coincides with the trailing edge of the PWM pulse. This transformation is achieved by a circuit consisting of an inverter and a NOR gate. In this circuit,  $\Delta t$  is equal to the delay time of the inverter.
3. A voltage or current source  $R$  that has a nonlinear waveform is connected to capacitance  $C$  through a switch  $SW$ . The switch  $SW$  is switched by the PPM signal, and is on during period  $[T, T + \Delta t]$ .

### B. Circuits for Discrete Dynamical Systems

Let  $R$  be a voltage source and its voltage waveform is given by  $f(t - \Delta t)$ . When the switch  $SW$  is turned off at the trailing edge of the PPM pulse, the voltage of the capacitor node,  $V_{out}$ , is kept at  $f(T)$ . Here, the charging time constant must be small enough compared with  $\Delta t$ . Thus, the following nonlinear transformation can be achieved in the appropriate scaling:

$$V_{out} = f(V_{in}). \quad (1)$$

In this circuit configuration, we can directly feed the PWM pulse into switch  $SW$ . However, the power consumption increases compared with the case of using

the PPM pulse because the capacitor is always charged or discharged during time period  $[0, T]$ .

When the output  $V_{out}$  is fed back to the input  $V_{in}$ , the following discrete-time dynamical system can be implemented:

$$V_{out}(t + 1) = f(V_{out}(t)). \quad (2)$$

### C. Circuits for Solving Difference Equations

Let  $R$  be a current source and its current waveform is given by  $Cf(t - \Delta t)$ . Because the capacitor is charged up only during period  $[T, T + \Delta t]$ , the following discrete-time transformation can be achieved.

$$V_{out}(t + 1) = V_{out}(t) + \int_T^{T+\Delta t} f(t - \Delta t) dt. \quad (3)$$

When  $\Delta t$  is enough small,

$$\Delta V_{out} \equiv V_{out}(t + 1) - V_{out}(t) \quad (4)$$

$$= f(T)\Delta t. \quad (5)$$

Thus, we obtain

$$\Delta V_{out} = f(V_{in})\Delta t. \quad (6)$$

When the output  $V_{out}$  is fed back to the input  $V_{in}$ , we can implement the discrete-time dynamical systems expressed by the difference equation:

$$\Delta V_{out} = f(V_{out})\Delta t. \quad (7)$$

Furthermore, if  $\Delta t$  is small enough and the Lipschitz's condition is satisfied, we can implement the continuous-time dynamical systems expressed by the differential equation:

$$\frac{dV_{out}(t)}{dt} = f(V_{out}(t)). \quad (8)$$

Since plural nonlinear current sources can be connected to the capacitor in parallel, dynamical systems with plural variables are also implemented. A circuit example will be shown in Sec. III-B.

### D. Expanded Functions

In the basic circuit described in Sec. II-A, a nonlinear monotone waveform  $g(t)$  can be used as  $V_{ramp}$ . Because  $T = g^{-1}(V_{in})$ , instead of Eq. (1) and (6), the implemented transformations are

$$V_{out} = f(g^{-1}(V_{in})), \quad (9)$$

and

$$\Delta V_{out} = f(g^{-1}(V_{in}))\Delta t, \quad (10)$$

respectively. This function can be used for realizing complex transfer functions.

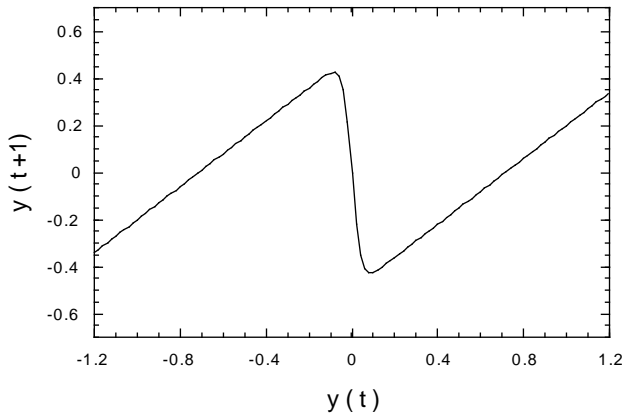

Figure 2: Return map of  $y(t)$  in chaotic neuron model

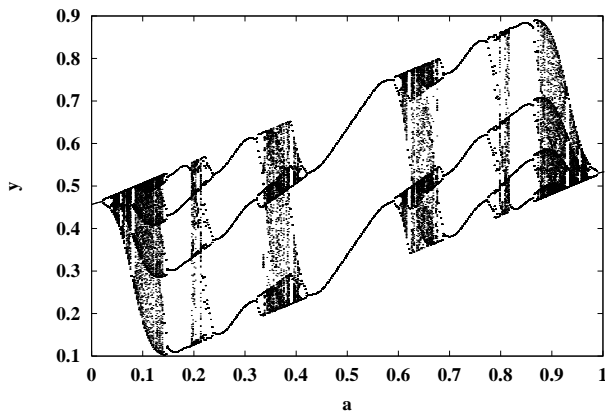

Figure 3: Bifurcation diagram in chaotic neuron model (SPICE simulation)

The circuits described above treat the voltage input and output. However, because a voltage input is converted into PWM and PPM signals at the first stage, the circuits can easily be modified in order to treat the PWM or PPM input and output. When a feedback loop is used, we can simultaneously obtain outputs in the three modes: voltage, PWM and PPM pulses. The voltage output is preferable for measuring the output value, while PWM signals are preferable for long signal transmission because PWM signals are robust against disturbances such as noise and crosstalk.

### E. Features of the Proposed Circuits

The proposed circuits can implement arbitrary nonlinear transformation and nonlinear dynamics. They use only one comparator and one reference waveform for the voltage-pulse conversion, do not need plural inverse function waveforms as in the previous circuits[1]. Therefore, the new circuits attain less power consumption and much simpler circuit configuration includ-

ing the control system. The simple configuration also leads to higher precision.

It is fairly easy to generate arbitrary non-monotone waveforms as a function of time by using various relaxation oscillator circuits or D/A converters, whereas it is very difficult to generate arbitrary nonlinear transfer functions by using ordinary analog circuits in voltage or current domains. Furthermore, plural transformation circuits can use a common nonlinear waveform generator, provided synchronous operation is assumed. Thus, the proposed circuits are much suitable for LSI implementation of large-scale nonlinear dynamical systems.

## III. CIRCUIT EXAMPLES AND SIMULATION RESULTS

### A. Example of Discrete Dynamical Systems: Chaotic Neuron

The dynamics of a chaotic neuron [4] is given by

$$\begin{aligned} y(t+1) &= ky(t) - \alpha u(y(t)) + a, \\ x(t+1) &= u(y(t+1)), \end{aligned} \quad (11)$$

where  $y(t)$  and  $x(t)$  are the internal state and the output of the neuron at the discrete time  $t$ , respectively;  $k$ ,  $\alpha$  and  $a$  are constants, and  $u(y)$  is a logistic function.

$$u(y) = \frac{1}{1 + \exp(-y/\varepsilon)}, \quad (12)$$

where  $\varepsilon$  is a constant. Figure 2 shows a return map of  $y(t)$ , where  $k = 0.7$ ,  $\alpha = 1$ ,  $a = 0.5$ , and  $\varepsilon = 0.02$ .

A bifurcation diagram obtained from the SPICE simulation is shown in Fig. 3. We obtained similar results to those in the numerical simulation [4].

### B. Example of Continuous-Time Dynamical Systems: Nonlinear Oscillator

We propose a nonlinear oscillator circuit. The oscillator model implemented is *locally excitatory, globally inhibitory oscillator networks (LEGION)* for image segmentation [5].

The key part of the oscillator dynamics is represented by the following equations with two variables,  $x_i$  and  $y_i$ ;

$$\begin{aligned} \frac{dx_i}{dt} &= 3x_i - x_i^3 + 2 - y_i + A_i, \\ \frac{dy_i}{dt} &= \varepsilon[\gamma(1 + \tanh(x_i/\beta)) - y_i], \end{aligned} \quad (13)$$

where  $\varepsilon$ ,  $\gamma$ , and  $\beta$  are constants, and  $A_i$  represents external signals.

In order to implement this model in our circuits, we changed these equations into difference ones by using Euler's discretization method. The block diagram of the oscillator circuit is shown in Fig. 4.

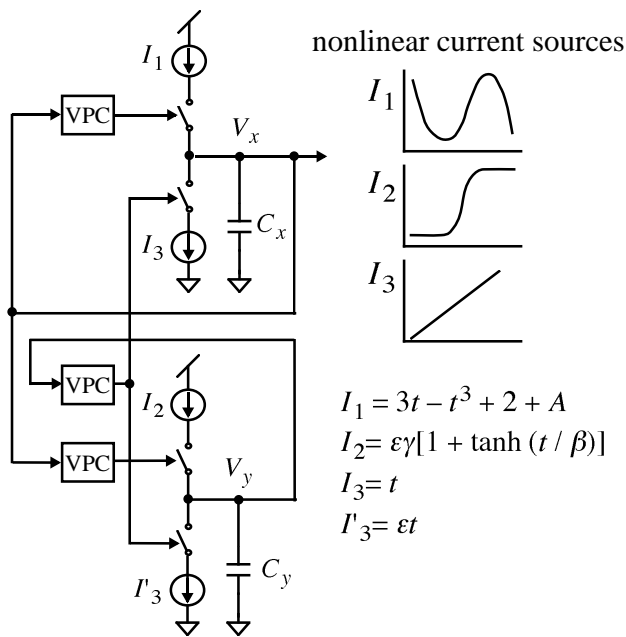

Figure 4: Oscillator circuit based on PPM method.

The values of  $x_i$  and  $y_i$  are represented by voltages  $V_x$  and  $V_y$ , and are stored as charges in capacitors  $C_x$  and  $C_y$ , respectively. The third-order function of  $x_i$  in Eq. (13) is generated by nonlinear current source  $I_1$ . The tanh function of  $y_i$  is generated by  $I_2$ . The contributions of the linear terms about  $y_i$  are generated by linear current sources  $I_3$  and  $I'_3$ . All PPM signals switch the (non)linear current sources, and charges stored in  $C_x$  and  $C_y$  are modified in each time step.

Circuit simulation (SPICE) results of the oscillator circuit are shown in Fig. 5. The device parameters used are based on a 0.4  $\mu\text{m}$  CMOS process, the sup-

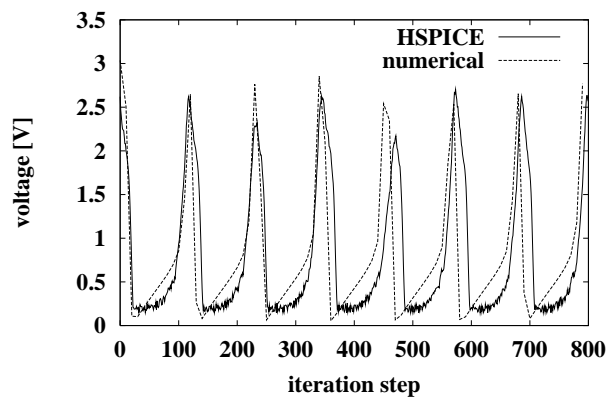

Figure 5: SPICE simulation results of oscillator circuit

ply voltage is 3.3 V, and the clock period is 1  $\mu\text{sec}$ . The SPICE simulation results show the expected oscillation, it is thus confirmed that the circuit correctly implements the dynamics shown in Eq. (13).

#### IV. CONCLUSION

We proposed new circuit techniques for nonlinear dynamical systems using PWM/PPM methods. The proposed circuits implement discrete-time continuous-state dynamics by analog processing in time domain although almost all circuit components are digital devices.

As examples of nonlinear dynamical circuits using the proposed techniques, a chaotic neuron circuit and a nonlinear oscillator circuit were proposed. The SPICE simulation results were very close to the results expected from high-precision numerical calculation.

The proposed approach is suitable for large-scale integration of analog dynamical systems because the circuit components can be shrunk with the scaling trend in the Si CMOS technology and low voltage and lower power operation is achieved.

#### ACKNOWLEDGMENT

This work was supported by the Ministry of Education, Science, Sports, and Culture under Grant-in-Aid for Scientific Research on Priority Areas (Number: 269).

#### References

- [1] T. Morie, S. Sakabayashi, M. Nagata, and A. Iwata, "Nonlinear function generators and chaotic signal generators using a pulse-width modulation method," *Electron. Lett.*, vol. 33, no. 16, pp. 1351–1352, 1997.
- [2] T. Morie, H. Ando, S. Sakabayashi, M. Nagata, and A. Iwata, "A new PWM technique implementing arbitrary nonlinear dynamics and its application to oscillator neurons," *The 2nd R.I.E.C. Int. Symp. on DAIPS*, pp. 275–278, Sendai, 1998.
- [3] A. Iwata and M. Nagata, "A concept of analog-digital merged circuit architecture for future VLSI's," *IEICE Trans. Fundamentals.*, vol. E79-A, no. 2, pp. 145–157, 1996.
- [4] K. Aihara, T. Takabe, and M. Toyoda, "Chaotic neural networks," *Phys. Lett. A*, vol. 144, pp. 333–340, 1990.
- [5] D. L. Wang and David Terman, "Image segmentation based on oscillatory correlation," *Neural Computation*, vol. 9, no. 4, pp. 805–836, 1997.